

### Positive Displacement Blower Silencers

#### Application

This combination reactive/ absorptive silencer is used typically on the discharge of positive displacement blowers in applications where the blower operates above the critical PLV or when the noise level criteria of the blower is stringent.

Typical Attenuation Curve

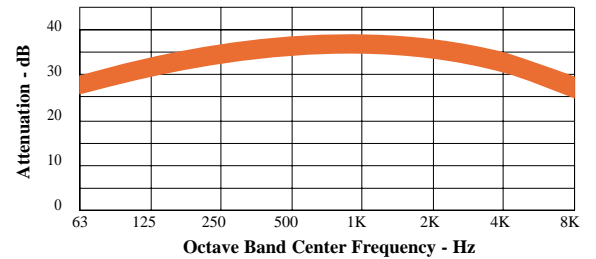

#### Dimensions

Model	A	B	D	F(min)	F(max)	G	H	Wt.
410-5301*	1½	7	32	6	11	9½	29	49
410-5302*	2	8	36	7½	14	10	33	66
410-5303*	2½	10	40	8½	16	12	37	87
410-5304*	3	10	48	9	19	12	45	114
410-5305*	3½	12	52	10	21	13	49	140
410-5306	4	14	56	10	22	13	52	174
410-5307	5	16	66	10	28	14	62	227
410-5308	6	18	72	12	32	16	68	478
410-5309	8	22	96	14	39	19	92	657
410-5310	10	26	120	15	47	20	116	1021
410-5311	12	30	136	17	55	23	132	1675
410-5312	14	36	160	20	59	27	155	2000
410-5313	16	40	172	22	62	29	167	2373
410-5314	18	45	184	24	71	32	179	3159
410-5315	20	50	200	25	84	35	195	3958
410-5316	22	54	212	27	89	37	207	4592
410-5317	24	54	236	29	102	37	231	5507
410-5318	26	60	260	30	112	40	255	6422
410-5319	28	68	280	32	125	46	275	7831
410-5320	30	72	300	35	130	48	295	8854

#### Performance Class Rating

Class	Minimum IL <sub>A</sub>
1	10 dBA
2	15 dBA
3	20 dBA
4	25 dBA
5	30 dBA
6	35 dBA
7	40 dBA
8	45 dBA

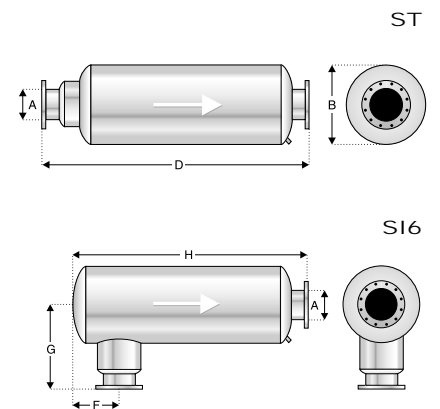

\*NPT Connections  
Finish-Primer Gray  
All flange connections - 150# ANSI

Dimensions in inches, weight in pounds.

Dimensions and weights are nominal and may vary slightly in production models.  
Request a certified drawing of a specific model for exact dimensions.

Lit-0095 99-05

# Silencer Selection Guide

The following information will enable you to determine the appropriate silencers for your blower application.

## Silencer Size

Table 1 provides the normal capacity of Silex silencers, in CFM. The sizes in Column 1 refer to the inlet sizes of silencers, in inches. Capacities are expressed in inlet CFM. Find the column which is equal to or greater than the operating pressure of your blower and then, from that column, find the value which is equal to or greater than the blower's CFM. The appropriate size is the value shown in column 1 of the table.

Calculate the back pressure of your blower using table 3 and formula at right

**Table 1**

		Capacity (Inlet CFM 14.7 PSI & °F)					
Size	Inlet Silencer	Discharge Silencer					
		4 PSIG	6 PSIG	8 PSIG	10 PSIG	12 PSIG	15 PSIG
1	38	39	40	41	43	44	45
1.5	85	88	91	93	96	98	101
2	151	157	161	165	171	174	180
2.5	237	245	252	259	267	273	281
3	341	352	363	372	383	392	404
3.5	464	480	494	507	523	534	550
4	605	625	644	660	681	696	716
5	944	977	1006	1032	1064	1088	1120
6	1360	1408	1450	1488	1534	1568	1614
8	2423	2507	2582	2649	2731	2792	2874
10	3783	3915	4032	4137	4265	4360	4488
12	5449	5639	5808	5959	6143	6280	6464
14	7427	7687	7917	8123	8373	8560	8811
16	9648	9985	10285	10552	10878	11120	11446
18	12286	12715	13096	13437	13851	14160	14575
20	15132	15661	16130	16550	17060	17440	17952
22	18325	18965	19533	20042	20660	21120	21740
24	21796	22557	23233	23838	24573	25120	25857
26	25544	26436	27228	27937	28799	29440	30304
28	29709	30746	31668	32492	33494	34240	35245
30	34082	35272	36329	37275	38424	39280	40433
Est. Temp.							
	70°F	115°F	140°F	165°F	190°F	200°F	240°F

## Silencer Type

Table 2 groups Silex silencers by silencer type. Determine which models are appropriate for your application based on whether the inlet and/or discharge speeds are above or below transition speeds. If the application has a critical noise specification, use a combination reactive/absorptive model.

**Table 2**

Pitch Line Velocity	Inlet	Discharge
Below Transition	Class 4	Class 4
	Class 5	Class 5
		Class 6
Above Transition	Class 4	Class 4
	Class 5	Class 5
		Class 6

## Pressure Drop

Table 3 sets out the pressure drop coefficients for Silex blower silencers. Use these coefficients in the equations to calculate the silencer pressure drop.

**Table 3**

Type	Silencer Model	Straight Thru	Side Inlet
Intake Silencers	Class 4	4.20	4.60
	Class 5	4.80	5.30
	Class 7	5.50	6.00
Discharge Silencers	Class 4	4.20	4.60
	Class 5	4.80	5.30
	Class 6	5.20	5.70
	Class 7	5.50	6.00
Absorptive Silencers	Class 4	0.20	-
	Class 5	0.75	-
	Class 6	0.80	-
	Class 7	0.85	-

### Pressure Drop

The following formulas may be used to calculate pressure drop through the silencers covered in this catalog.

$$\text{Inlet } \Delta P = \left( \frac{v}{4005} \right)^2 c$$

(assumes silencer inlet is open to atmosphere)

$$\text{Discharge } \Delta P = \left( \frac{v}{4005} \right)^2 c \times \frac{P}{14.7} \times \frac{530}{T}$$

$\Delta P$  = Pressure drop through silencer, inches, H<sub>2</sub>O

$V$  = Air velocity through silencer, feet per minute

$C$  = Individual Silencer restriction coefficient - empirical constant (See Table 3)

$T$  = Discharge temperature, °R. absolute (operating temperature in degrees F + 460)

$P$  = Discharge pressure, PSIA (operating pressure in PSIG + 14.7)



Silex Inc. Phone 905 612 4000  
 6659 Ordan Drive Fax 905 612 8999  
 Mississauga, Ontario Web www.silex.com  
 L5T 1K6 E-mail info@silex.com