

Positive Displacement Blower Silencers

Application

This reactive silencer is used typically on the discharge of positive displacement blowers in applications where the blower operates below the critical Pitch Line Velocity.

Typical Attenuation Curve

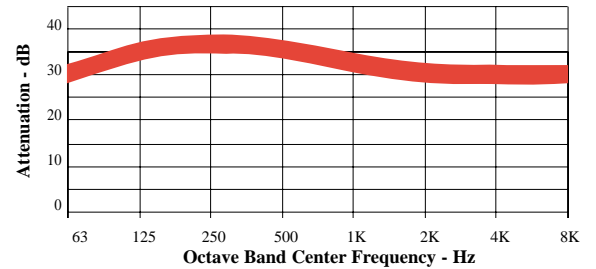

Dimensions

Model	A	B	D	F(min)	F(max)	G	H	Wt.
410-6101*	1½	9	36	3	11	7½	30	50
410-6102*	2	10	40	4½	11	9	37	64
410-6103*	2½	12	46	5½	15	10	43	90
410-6104*	3	14	50	6	21	11	47	116
410-6105*	3½	16	54	7	25	12	51	147
410-6106	4	18	64	7	31	13	60	207
410-6107	5	22	72	9	35	16	68	438
410-6108	6	26	85	11	41	17	81	611
410-6109	8	30	103	12	50	19	99	921
410-6110	10	36	118	14	59	23	114	1317
410-6111	12	36	142	14	59	23	138	1861
410-6112	14	40	145	17	60	25	140	2263
410-6113	16	45	164	19	63	28	159	2881
410-6114	18	50	188	21	74	30	183	3849
410-6115	20	54	217	22	87	32	212	4843
410-6116	22	60	230	24	92	35	225	5651
410-6117	24	64	258	26	105	38	253	6778
410-6118	26	68	283	27	115	40	278	7929
410-6119	28	72	315	29	128	42	310	9427
410-6120	30	78	326	32	133	45	321	10624

Performance Class Rating

Class	Minimum IL _A
1	10 dBA
2	15 dBA
3	20 dBA
4	25 dBA
5	30 dBA
6	35 dBA
7	40 dBA
8	45 dBA

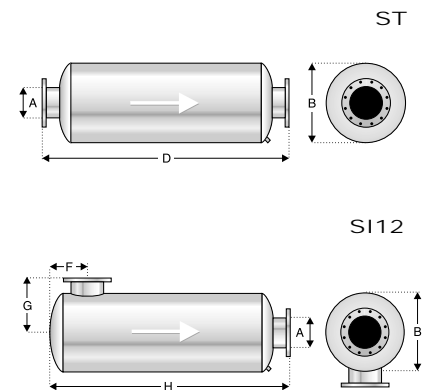

*NPT Connections
Finish-Primer Gray
All flange connections - 150# ANSI

Dimensions in inches, weight in pounds.

Dimensions and weights are nominal and may vary slightly in production models.
Request a certified drawing of a specific model for exact dimensions.

Lit-0091 99-05

Silencer Selection Guide

The following information will enable you to determine the appropriate silencers for your blower application.

Silencer Size

Table 1 provides the normal capacity of Silex silencers, in CFM. The sizes in Column 1 refer to the inlet sizes of silencers, in inches. Capacities are expressed in inlet CFM. Find the column which is equal to or greater than the operating pressure of your blower and then, from that column, find the value which is equal to or greater than the blower's CFM. The appropriate size is the value shown in column 1 of the table.

Calculate the back pressure of your blower using table 3 and formula at right

Table 1

		Capacity (Inlet CFM 14.7 PSI & °F)					
Size	Inlet Silencer	Discharge Silencer					
		4 PSIG	6 PSIG	8 PSIG	10 PSIG	12 PSIG	15 PSIG
1	38	39	40	41	43	44	45
1.5	85	88	91	93	96	98	101
2	151	157	161	165	171	174	180
2.5	237	245	252	259	267	273	281
3	341	352	363	372	383	392	404
3.5	464	480	494	507	523	534	550
4	605	625	644	660	681	696	716
5	944	977	1006	1032	1064	1088	1120
6	1360	1408	1450	1488	1534	1568	1614
8	2423	2507	2582	2649	2731	2792	2874
10	3783	3915	4032	4137	4265	4360	4488
12	5449	5639	5808	5959	6143	6280	6464
14	7427	7687	7917	8123	8373	8560	8811
16	9648	9985	10285	10552	10878	11120	11446
18	12286	12715	13096	13437	13851	14160	14575
20	15132	15661	16130	16550	17060	17440	17952
22	18325	18965	19533	20042	20660	21120	21740
24	21796	22557	23233	23838	24573	25120	25857
26	25544	26436	27228	27937	28799	29440	30304
28	29709	30746	31668	32492	33494	34240	35245
30	34082	35272	36329	37275	38424	39280	40433
Est. Temp.							
	70°F	115°F	140°F	165°F	190°F	200°F	240°F

Silencer Type

Table 2 groups Silex silencers by silencer type. Determine which models are appropriate for your application based on whether the inlet and/or discharge speeds are above or below transition speeds. If the application has a critical noise specification, use a combination reactive/absorptive model.

Table 2

Pitch Line Velocity	Inlet	Discharge
Below Transition	Class 4	Class 4
	Class 5	Class 5
		Class 6
Above Transition	Class 4	Class 4
	Class 5	Class 5
		Class 6

Pressure Drop

Table 3 sets out the pressure drop coefficients for Silex blower silencers. Use these coefficients in the equations to calculate the silencer pressure drop.

Table 3

Type	Silencer Model	Straight Thru	Side Inlet
Intake Silencers	Class 4	4.20	4.60
	Class 5	4.80	5.30
	Class 7	5.50	6.00
Discharge Silencers	Class 4	4.20	4.60
	Class 5	4.80	5.30
	Class 6	5.20	5.70
	Class 7	5.50	6.00
Absorptive Silencers	Class 4	0.20	-
	Class 5	0.75	-
	Class 6	0.80	-
	Class 7	0.85	-

Pressure Drop

The following formulas may be used to calculate pressure drop through the silencers covered in this catalog.

$$\text{Inlet } \Delta P = \left(\frac{v}{4005} \right)^2 c$$

(assumes silencer inlet is open to atmosphere)

$$\text{Discharge } \Delta P = \left(\frac{v}{4005} \right)^2 c \times \frac{P}{14.7} \times \frac{530}{T}$$

ΔP = Pressure drop through silencer, inches, H₂O

V = Air velocity through silencer, feet per minute

C = Individual Silencer restriction coefficient - empirical constant (See Table 3)

T = Discharge temperature, °R. absolute (operating temperature in degrees F + 460)

P = Discharge pressure, PSIA (operating pressure in PSIG + 14.7)



Silex Inc. Phone 905 612 4000
 6659 Ordan Drive Fax 905 612 8999
 Mississauga, Ontario Web www.sillex.com
 L5T 1K6 E-mail info@sillex.com