

## Features

The design of Silex isolators optimizes both vibration isolation efficiency and cost efficiency because the springs are interchangeable within the same housing.

## Application

The Silex Seismic Isolators are specially designed for use on stationary generator sets. Other uses include:

- Engine drive compressor sets
- Engine and motor driven pumps
- Utility sets
- Reciprocating compressors
- Refrigeration machines

## Seismic

## ISOLATORS

### Seismic Zones

Silex seismic isolators are designed according to the BOCA National Building Code/1999 and are especially designed for use in zone 4 but can be used in applications for zones 1-3.

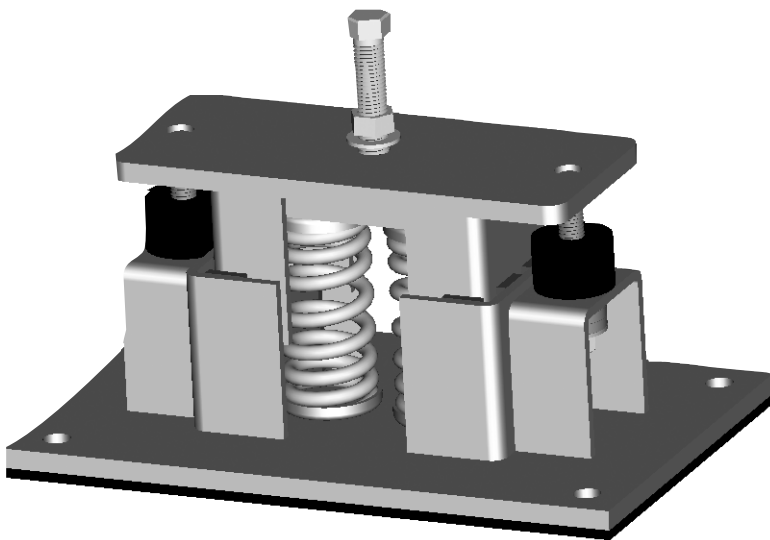

**Springs** — Oil Tempered and Chrome Silicon Steel is used on the standard springs.

**Internal Dampening** — All Silex isolators incorporate internal neoprene-shear rubber-sided dampening. This dampening limits the machine vibration while the engine passes through the start-up resonant frequency.

**Silex Sound Pad** — To provide a non-skid surface and to increase isolation efficiency, the Silex Sound Pad is installed on all isolators.

**Side Snubber** — Side snubber is standard .

**Level Adjusting Bolt** — All Silex isolators have an external adjustment that is long enough to accommodate a 2" base channel

## Dimensions

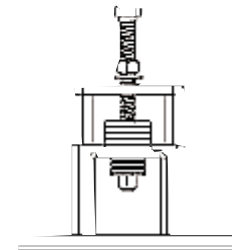
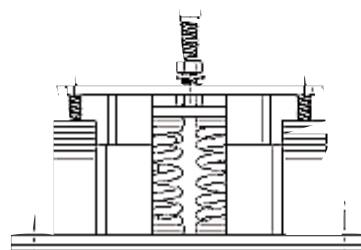
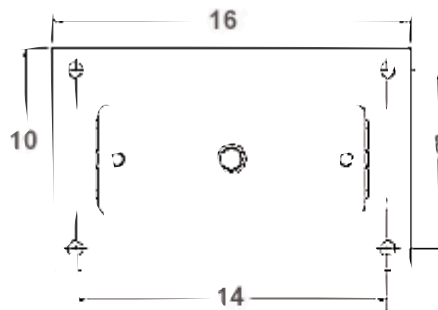

Silex Innovations Inc.  
Phone 905 612 4000  
Fax 905 612 8999  
[www.silex.com](http://www.silex.com)

# Order Information/Selection

## Technical

When installing a diesel engine generator set, or other rotating equipment, it is important to reduce vibration and structure borne noise to the building in which the engine is located. When designing an isolation system for a generator set some of the factors to consider include:

- Mass of equipment
- Mass of floor
- Stiffness of floor
- Vibratory force produced by equipment
- Frequency of rotating equipment
- Natural frequency of isolators
- Natural frequency of floor

## Spring Interchangeability

Silex isolators are designed to accommodate all of the different rated springs. This means you can change springs without changing other parts of the isolator, such as housings.

## Installation Instructions

1. Position isolator on a level surface under equipment leg
2. Insert adjusting bolt and screw down 2 complete turns on each isolator alternatively until equipment is at required level.
3. Tighten lock nut securely to equipment leg.
4. Anchor bolts must be SAE Grade 5 or higher.

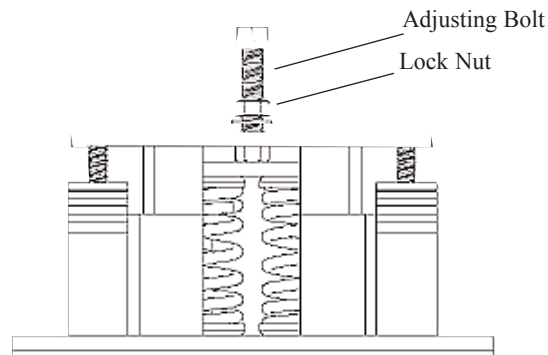

Spring Colour	Part No.	Load (Lbs)	Weight (Lbs)
Orange	SMD2-2500-S4	2500	50.0
Green	SMD2-2900-S4	2900	50.0
Yellow	SMD2-3600-S4	3600	50.0
Beige	SMD2-4400-S4	4400	51.0
Red	SMD2-5000-S4	5000	52.0
Navy	SMD2-6000-S4	6000	52.0