

Spring

ISOLATORS

Features

The design of Silex isolators optimizes both vibration isolation efficiency and cost efficiency because the springs are interchangeable within the same housing.

Application

The Silex Spring Isolators are specially designed for use on stationary generator sets. Other uses include:

- Engine drive compressor sets
- Engine and motor driven pumps
- Utility sets
- Reciprocating compressors
- Refrigeration machines

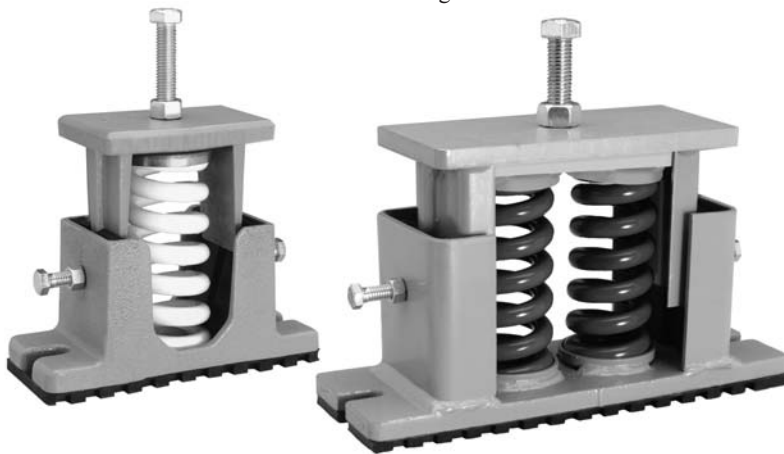

- 1-2. **Housing Materials** — Ductile cast iron is standard on the single spring isolators. Cold rolled steel plate is used for the dual spring isolators.
3. **Springs** — Oil Tempered and Chrome Silicon Steel is used on the standard springs.
4. **Internal Dampening** — All Silex isolators incorporate internal neoprene-shear rubber-sided dampening. This dampening limits the machine vibration while the engine passes through the start-up resonant frequency.
5. **Silex Sound Pad** — To provide a non-skid surface and to increase isolation efficiency, the Silex Sound Pad is installed on all isolators.
6. **Side Snubber** — Side snubber is standard on the SMD and SMD2 models.
7. **Level Adjusting Bolt** — All Silex isolators have an external adjustment that is long enough to accommodate a 2" base channel

Dimensions

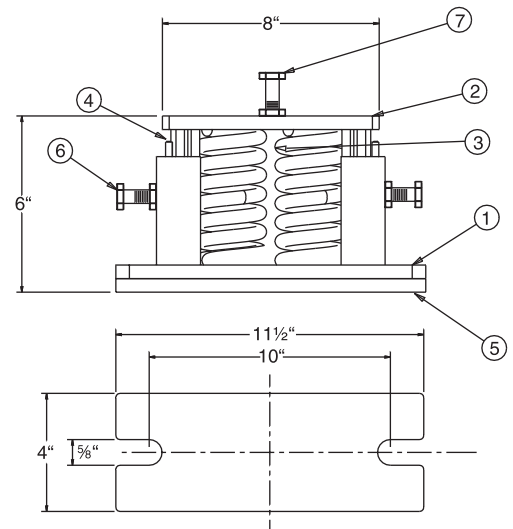
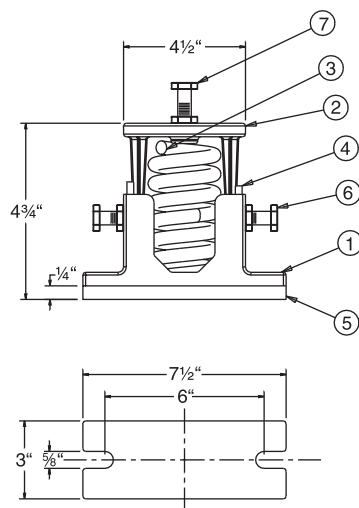

Silex Innovations Inc.
Phone 905 612 4000
Fax 905 612 8999
www.silex.com

Lit-0020 04-05

one source ... one supplier
800 387 7818

Order Information/Selection

Technical

When installing a diesel engine generator set, or other rotating equipment, it is important to reduce vibration and structure borne noise to the building in which the engine is located. When designing an isolation system for a generator set some of the factors to consider include:

- Mass of equipment
- Mass of floor
- Stiffness of floor
- Vibratory force produced by equipment
- Frequency of rotating equipment
- Natural frequency of isolators
- Natural frequency of floor

Spring Interchangeability

Silex isolators are designed to accommodate all of the different rated springs. This means you can change springs without changing other parts of the isolator, such as housings.

Installation Instructions

1. Position isolator on a level surface under equipment leg
2. Loosen adjustable snubbers to allow full deflection (Model SMD)
3. Insert adjusting bolt and screw down 2 complete turns on each isolator alternatively until equipment is at required level.
4. Tighten lock nut securely to equipment leg.

The following steps are for Model SMD only.

5. Tighten adjustable snubber bolts finger tight.
6. Operate the equipment. If movement is excessive tighten snubber bolts 1/4 turn at a time on each isolator until movement is at allowable level.

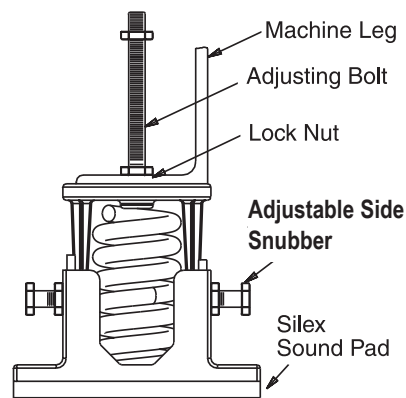

Spring Colour	Single Spring Isolator				Double Spring Isolator			
	Part No.	Without Side Snubber	With Side Snubber	Load Weight (Lbs)	Part No.	Without Side Snubber	With Side Snubber	Load Weight (Lbs)
Blue	SM-150	SMD-150	150	8.0	SM2-300	SMD2-300	300	18.0
Grey	SM-250	SMD-250	250	8.0	SM2-500	SMD2-500	500	18.0
Pink	SM-450	SMD-450	450	8.0	SM2-900	SMD2-900	900	18.0
Black	SM-550	SMD-550	550	9.0	SM2-1100	SMD2-1100	1100	20.0
White	SM-750	SMD-750	750	9.0	SM2-1500	SMD2-1500	1500	20.0
Brown	SM-1050	SMD-1050	1050	9.0	SM2-2100	SMD2-2100	2100	20.0
Orange	SM-1250	SMD-1250	1250	9.0	SM2-2500	SMD2-2500	2500	20.0
Green	SM-1450	SMD-1450	1450	9.0	SM2-2900	SMD2-2900	2900	20.0
Yellow	SM-1800	SMD-1800	1800	9.0	SM2-3600	SMD2-3600	3600	20.0
Beige	SM-2200	SMD-2200	2200	10.0	SM2-4400	SMD2-4400	4400	21.0
Red	SM-2500	SMD-2500	2500	10.0	SM2-5000	SMD2-5000	5000	22.0
Navy	SM-3000	SMD-3000	3000	11.0	SM2-6000	SMD2-6000	6000	22.0

Silex Innovations Inc.
 Phone 905 612 4000
 Fax 905 612 8999
www.silex.com

Lit-0020 04-05

one source ... one supplier™
800 387 7818